

Gear motors

EC-motor with planetary gearing for automated spindle positioning cycles

BG650 - planetary gearing



BG650

Technical data - electrical ratings

Voltage supply	24 (20...30) VDC
Residual ripple	<5 %
Nominal current	4 A, 5.6 A, 7.8 A
Nominal rating	65 W, 100 W, 140 W
Undervoltage shutdown	≤19 V
External backup	8 AT (required)
Overheat protection	110 °C (final power output circuit)
Peak current	≤27 A
Control signals	Rotation speed 1 Rotation speed 2 Counterclockwise Clockwise Enable
Outputs	Motor malfunction (Error)
Inputs	Enable Start counterclockwise Start clockwise

Features

- Brushless EC-DC motor
- With integrated rotation speed electronics
- Nominal power 65 W, 100 W or 140 W
- Direct connection to spindle position display

Technical data - mechanical design

Shaft type	∅12 mm solid shaft
Operating temperature	-10...+50 °C
Protection DIN EN 60529	IP 54
Connection	- Round connector 8-pin, motor supply - Round connector 12-pin, between motor - SPA DIN45326, Binder series 723
Nominal torque	≤8 Nm (with 65 W) ≤12 Nm (with 100 W) ≤16 Nm (with 140 W)
Starting torque	≤40 Nm (with 65 W) ≤60 Nm (with 100 W) ≤130 Nm (with 140 W)
Operating speed	≤72 rpm (highspeed) ≤4 rpm (slowspeed)
Scaling ratio	50:1
Number of stages	2
Efficiency (factor)	0.81
Shaft loading	≤500 N axial ≤350 N radial
Dimensions	∅52 x 176.5 mm (BG650.25) ∅52 x 201.5 mm (BG650.50) ∅52 x 226.5 mm (BG650.75)
Weight approx.	1670 g (type: BG650.25), 2020 g (type: BG650.50), 2520 g (type: BG650.75)
Material	Aluminium profile, anodized in black

Gear motors

EC-motor with planetary gearing for automated spindle positioning cycles

BG650 - planetary gearing

Part number

BG650. 0 52 01

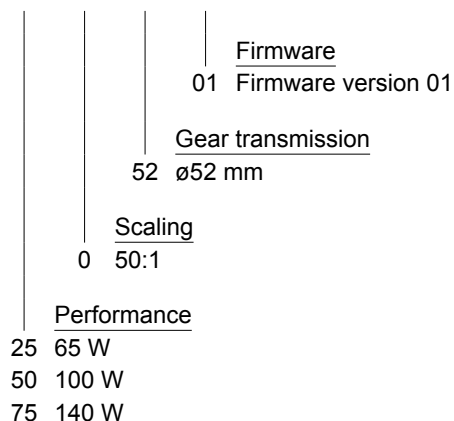

Description

Motors of the BG650 series are EC motors (brushless DC-motors) with integrated rotation speed electronics. BG650 series comprises three designs with different dimensions and output power of 65 W, 100 W and 140 W. The EC motor featuring a fully assembled planetary gearing is a compact drive in electric spindle positioning operations of the multiconDrive system.

It provides a separate round connector output enabling direct motor connection to the spindle position display (N 142, N 152). This "interface" provides the motor with control signals for "clockwise", "counterclockwise" and "off" as well as with a signal for recalling two permanent motor speed parameters relating to high and low speed. Already pre-defined ramps for acceleration respectively deceleration secure smooth motor start and slow-down.

Accessories

Connectors and cables

Z 165.M01	Motor supply cable 1.5 m, 8-pin mating connector
Z 165.M02	Motor supply cable 3 m, 8-pin mating connector
Z 165.M03	Motor supply cable 10 m, 8-pin mating connector

Gear motors

EC-motor with planetary gearing for automated spindle positioning cycles

BG650 - planetary gearing

Terminal assignment

Connector – Motor, 8-pin

Connector	Assignment	Function
Pin 1	U _E	+24 VDC motor supply
Pin 2	GND	0 V related to ground für U _E
Pin 3	OUT left	Release counterclockwise
Pin 4	IN left	Release counterclockwise
Pin 5	OUT right	Release clockwise
Pin 6	IN right	Release clockwise
Pin 7	Enable	Logic +24 V
Pin 8	n.c.	n.c.

Connector – SPA, 12-pin

Connector	Assignment	Function
Pin A	–	–
Pin B	IN 1	Motor left
Pin C	IN 2	Motor right
Pin D	IN 4*	Speed
Pin E	+24 V	n.c.
Pin F	n.c.	n.c.
Pin G	n.c.	n.c.
Pin H	–	n.c.
Pin J	–	n.c.
Pin K	OUT 3	Error signal
Pin L	IN 3*	Speed
Pin M	GND	GND

IN 3*	IN 4*	Rotation speed
1	0	200
1	1	3600

Circuit diagram

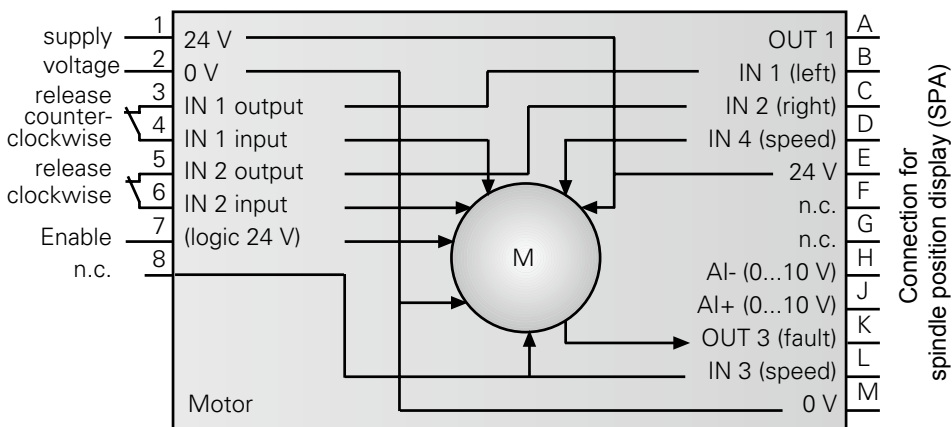

Connection for
spindle position display (SPA)

Gear motors

EC-motor with planetary gearing for automated spindle positioning cycles

BG650 - planetary gearing

Dimensions

